



# **Arboricultural Impact Assessment**

## **Corinthian Park, Grovesfield Way, Cheltenham**

**Report Reference Number: 180516-1.3-CP-AIA-MW**

On behalf of

**Hinton Properties (Grovesfield) Ltd**

**16 May 2018**

# Arboricultural Impact Assessment

Corinthian Park, Grovefield Way, Cheltenham



---

## Document Control Sheet

**Project Name:** Corinthian Park, Grovefield Way, Cheltenham

**Report Ref:** 180516-1.3-CP-AIA-MW

**Title:** Arboricultural Impact Assessment

	Name	Position	Date
Prepared by:	Mike Wood	Senior Arboricultural Consultant	27/02/2018
Surveyed by:	James Covenant	Arboricultural Surveyor	20/02/2018

Revision	Date	Description	Prepared by
1.1	27/02/2018	Draft	MW
1.2	08/03/2018	Final for submission	MW
1.3	16/05/2018	Size of Retail Store Altered	MW

---

## **Table of Contents**

<b>Executive Summary</b>	<b>1</b>
<b>1 Introduction</b>	<b>2</b>
1.1 Brief and Context	2
1.2 Purpose of this Report	2
1.3 The Development	3
<b>2 Existing Tree Population and Constraints</b>	<b>3</b>
<b>3 Arboricultural Impact of the Proposals</b>	<b>4</b>
3.1 Tree Removal and Retention	4
3.2 Facilitative Tree Works	5
3.3 Tree Protection	5
3.4 Additional Precautions	6

**Appendix A – Tree Schedule**

**Appendix B – Tree Protection Plan**

**Appendix C – Tree Constraints Plan**

**Appendix D – Tree Protection Specifications**

**Appendix E – Tree Survey Method and Limitations**

### Executive Summary

- This report provides an assessment of the impact of the proposal for a *Hybrid Application* for; Full Application (in respect of the south eastern portion of the site) for the development of 5,034 sqm of commercial office space (Use Class B1), 502 sqm day nursery (Use Class D1), 1742 sqm discount retail unit (Class A1) a 204 sqm Costa Coffee retail unit and drive thru (proposed use classes currently A1, A3 and A5), with associated parking, landscaping and infrastructure works and Outline Application for the erection of 8,034 sqm of commercial office space (Use Class B1) upon on site trees and relevant off-site trees, and makes recommendations for mitigating any negative impacts. It is suitable for submission in support of a planning application.
- 39 individual trees and 7 tree groups' tree features were surveyed. The data for each is presented within the Tree Schedule at Appendix A.
- 3 trees (T25, T28, T35,) have been identified for removal to facilitate the development. 2 of these trees are 'U' category and the remaining tree (T28) is 'C' category according to BS5837:2012.
- A further 5 category 'U' trees are recommended for removal (T12, T14, T43, T45, T46), however these trees do not conflict with the development, so are not listed in the trees identified for removal. These trees are young and have failed to establish. Replacement would be beneficial.
- The remaining 43 tree features will be retained, protected and integrated into the development. Sufficient space and adequate protection measures have been set out to ensure that retained trees are not damaged during the pre-construction and construction phase and to enable their successful development post-construction. Retained tree protection measures are discussed throughout this report and illustrated on the Tree Protection Plan at Appendix B.
- T27 will be subject to construction within the root protection area. This is minor encroachment of the RPA (<10%), therefore this construction work is not considered to be damaging providing the tree protection fencing is correctly installed and maintained.
- No remedial tree work is anticipated to retained trees to facilitate the development and/or to reduce the likelihood of their being subject to excessive pressure after the completion of the development.

### **1 Introduction**

#### **1.1 Brief and Context**

1.1.1 Treework Environmental Practice has been instructed by Hinton Properties (Grovefield) Ltd to provide an Arboricultural Impact Assessment, in accordance with British Standard BS5837: 2012 *Trees in Relation to Design, Demolition and Construction – Recommendations*, of the effect of development proposals on trees at Corinthian Park, Grovefield Way, Cheltenham.

1.1.2 Trees are a material consideration for a Local Planning Authority when determining planning applications, whether or not they are afforded the statutory protection of a Tree Preservation Order or Conservation Area. British Standard BS 5837:2012 *Trees in Relation to Design, Demolition and Construction* sets out the principles and procedures to be applied to achieve a harmonious and sustainable relationship between trees and new developments. The Standard recommends a sequence of activities that starts in the initial feasibility and design phase (RIBA Stage 2 'Concept Design') with a survey to qualify and quantify the trees on site and establish the arboricultural constraints to development (above- and below-ground) to inform the design in an iterative process, and continues with an assessment of the arboricultural impacts of the final design and measures to mitigate such impacts should they be negative. Detailed technical specifications for mitigation and protection measures are devised in the design phase that follows (RIBA Stage 3-4 'Developed and Technical design'), and the sequence ends with the Implementation and Aftercare phase (RIBA Stages 5-7) with the implementation of those measures once planning permission is granted, guided by Arboricultural Method Statements (RIBA Stage 4-5, 'Technical Design and Construction') and professional guidance where appropriate.

1.1.3 This Arboricultural Impact Assessment (AIA) reports on the direct and indirect impacts of the proposed development on trees in terms of both the buildability of the proposals and the long-term impact of the finished scheme, and where necessary presents mitigation for these impacts.

#### **1.2 Purpose of this Report**

1.2.1 This AIA, and accompanying Tree Schedule and Tree Protection Plan, is provided to support a hybrid planning application for the proposed development. It sets out the arboricultural impacts of the proposals using the following considerations as a framework:

- Trees to be removed and trees to be retained.
- Remedial tree work to retained trees to allow development and ensure retained trees will form a harmoniously integrated component of the proposed development.
- Suitable measures to protect retained trees.

- Special construction or engineering measures required to enable trees to be harmoniously integrated into the proposed development.

### 1.3 The Development

1.3.1 The proposed development is a hybrid application for the following:

- Full Application (in respect of the south eastern portion of the site) for the development of 5,034 sqm of commercial office space (Use Class B1), 502 sqm day nursery (Use Class D1), 1742 sqm discount retail unit (Class A1) a 204 sqm Costa Coffee retail unit and drive thru (proposed use classes currently A1, A3 and A5), with associated parking, landscaping and infrastructure works.
- Outline Application for the erection of 8,034 sqm of commercial office space (Use Class B1) upon on site trees and relevant off-site trees, and makes recommendations for mitigating any negative impacts. It is suitable for submission in support of a planning application.

1.3.2 The following documents have been reviewed by Treework Environmental Practice to inform this report:

Document Title	Document/Drawing number	Originator
Topographical Survey	GFW-BWB-00-XX-M2-G-001_Existing_Site.dwg	BWB
Proposed Layout	178-96-Rev B- Site Block Plan	Design Development Partnership
Tree Protection Plan	180227-2.0-CPC-TPP-NC_MW	Treework Environmental Practice

## 2 Existing Tree Population and Constraints

2.1.1 The original survey covering trees on site and trees on adjacent land close enough to be affected by the development was undertaken on 12 September 2016. A further update survey was undertaken on 20<sup>th</sup> February 2018. The full survey results of the updated survey are presented in the Tree Schedule at Appendix A and Tree Constraints Plan at Appendix C.

2.1.2 The survey was undertaken based on trees plotted using an outline base map as reference in Treework Environmental Practice's specialist tree management software – MyTrees. The basemap contained a topographical survey of the trees. Trees and hedges were plotted on the basemap using the topographical survey as reference.

2.1.3 The proposed development site currently native trees and periphery hedgerow groups, to the south and east boundaries with woodland belt group to the north and newly planted Birch to the north east.

2.1.4 BS 5837:2012 recommends classifying trees into four quality and value categories to determine their relative retentive worth. A summary of the relative retentive worth of the trees on site as recorded during the tree survey and expressed by their categories is given in Table 1. Appendix A explains the BS 5837:2012 tree categorisation process.

**Table 1: Trees/Groups in each Retention Category**

BS Category	No. of Trees (T)	No. of Groups (G)	Total
A	0	0	0
B	5	1	6
C	27	6	33
U	7	0	7
<b>Total</b>	<b>39</b>	<b>7</b>	<b>46</b>

2.1.5 Trees present constraints to development both above and below ground. The above ground constraints comprise the physical extent of tree crowns. The below ground constraints comprise the roots, and are expressed in terms of the root protection area (RPA), which is the minimum rooting area that a tree needs to sustain itself in reasonable health. These constraints, as established by the tree-survey, inform this assessment of the impact of the development proposals.

2.1.6 The full results of the tree survey on which this report is based are given in the Tree Schedule at Appendix A, and the above- and below-ground constraints are illustrated on the Tree Protection Plan at Appendix B. Each tree (T) and tree group (G) has been allocated an individual number to which it is referred in this report and all associated documents. The survey method and limitations are set out in Appendix E.

### 3 Arboricultural Impact of the Proposals

#### 3.1 Tree Removal and Retention

3.1.1 The 3 tree features (T25, T28 and T35) proposed for removal to facilitate the proposed development are summarised in Table 2 by BS5837: 2012 category. Trees have been identified for removal where they come into direct conflict with the layout or considered unsustainable. All Category U trees should be removed due to their poor condition, which would be advisable regardless of the development proposal.

**Table 2 – Tree Features for Removal by BS Category**

Category A Trees/Groups	Category B Trees/Groups	Category C Trees	Category U Trees
0	0	T28	T25, T35
<b>0</b>	<b>0</b>	<b>1</b>	<b>2</b>

3.1.2 All trees other than those in Table 2 will be retained and protected during development (see section 3.3).

### 3.2 Facilitative Tree Works

3.2.1 None of the trees are anticipated to require any facilitative tree pruning work to enable the proposed development or to prevent future conflict, in relation to this layout.

### 3.3 Tree Protection

#### 3.3.1 *Root Protection Areas and Construction Exclusion Zones*

Retained trees will be protected during development by establishing a Construction Exclusion Zone (CEZ) around their Root Protection Areas (RPAs). RPAs are a layout design tool, indicating the minimum area around a tree deemed to contain sufficient roots and soil to maintain the tree’s viability. RPAs should be treated as a precautionary area within which activities such as ground compaction, excavation, the storing of materials, ground level changes and other construction activity are likely to cause damage to trees and should therefore be excluded. This CEZ can be achieved by the erection of barriers at the locations shown on the Tree Protection Plan at Appendix B. Tree protection barriers must be installed before any demolition or construction works start, and, unless approved by the Local Planning Authority or by an arboriculturist approved by them, should remain in place until all construction activity has been completed.

3.3.2 The type of barriers should match the level of activity around the retained trees. Where a high level of construction activity is expected, fencing must be braced to be robust to vehicular impact and to prevent it from being easily repositioned; a specification similar to drawing 3 in BS 5837:2012 will be suitable (reproduced at Appendix D). In areas away from the main construction activity and vehicle movement, it may be appropriate to install a lower specification fencing, examples of which are given at Appendix D.



3.3.3 All protection fencing should carry identifying signs that state its purpose and proscribe its removal until all demolition and construction work is complete. An example sign is given at Appendix D.

### **3.4 Additional Precautions**

#### **3.4.1 *Utilities and Services***

Information on the location of utility and service runs for the proposed development was not available at time of writing. In principle, traditional trench-installed utilities should be routed outside of the RPAs of retained trees to avoid root damage. Where routing utility runs within RPAs is unavoidable, all work should comply with The National Joint Utilities Volume 4 and advice should be sought from a professional Arboricultural Consultant.

#### **3.4.2 *Soft Landscaping***

The Arboricultural Consultant should review any landscape operations that involve any work within the RPAs of retained trees and input additional site specific methodology where necessary.

# Appendix A

---

## Tree Schedule

# Corinthian Park

## Tree Survey BS5837-2012



Tree/Group Reference	Tree Count	Species	Height (m)	Stem Count	Stem Diameter (cm)	Crown Radius (m)				Crown Clearance Height (m)	Lowest Branch Height (m)	Life Stage	Physiological Condition	Observations and Recommendations	RPA (m <sup>2</sup> )	RPR (m)	Remaining Contribution (Years)	Retention Category	Retention Sub-category
T1	1	<i>Fraxinus excelsior</i> Ash	7.0	4	21	N 2.5	E 3.0	S 2.5	W 2.5	2.0	2.0	Early Mature	Good	Altered ground level - Historic.	20.6	2.6	20-40	C	2
T2	1	<i>Acer pseudoplatanus</i> Sycamore	5.0	1	12	N 2.0	E 2.0	S 2.0	W 2.5	2.0	2.0	Semi Mature	Good	Altered ground level - Historic.	6.5	1.4	20-40	C	2
T3	1	<i>Fraxinus excelsior</i> Ash	6.5	1	14	N 3.0	E 2.0	S 1.0	W 1.5	2.5	2.0	Semi Mature	Good	Altered ground level - Historic. Decay entry points.	8.9	1.7	20-40	C	2
T4	1	<i>Acer pseudoplatanus</i> Sycamore	7.0	2	16	N 2.0	E 2.0	S 3.0	W 2.5	2.0	2.0	Semi Mature	Good	Altered ground level - Historic.	12.5	2.0	20-40	C	2
T5	1	<i>Prunus sp.</i> Cherry sp.	4.5	13	21	N 3.0	E 2.5	S 3.0	W 2.5	1.0	1.5	Semi Mature	Good	Altered ground level - Historic.	21.2	2.6	20-40	C	2
T6	1	<i>Fraxinus excelsior</i> Ash	6.0	3	20	N 2.5	E 3.0	S 2.5	W 2.0	3.0	2.0	Semi Mature	Good	Altered ground level - Historic.	19.9	2.5	20-40	C	2
T7	1	<i>Carpinus betulus</i> Hornbeam	5.0	1	21	N 3.5	E 3.0	S 3.5	W 2.5	1.0	1.5	Early Mature	Good	Altered ground level - Historic.	20.0	2.5	40+	B	2
T8	1	<i>Fraxinus excelsior</i> Ash	6.5	1	12	N 2.0	E 3.0	S 1.5	W 0.5	2.0	3.0	Semi Mature	Good	Altered ground level - Historic. Leaning trunk - Major.	6.5	1.4	20-40	C	2
T9	1	<i>Carpinus betulus</i> Hornbeam	6.5	1	20	N 3.0	E 3.5	S 2.0	W 3.0	2.0	2.0	Semi Mature	Good	Altered ground level - Historic.	18.1	2.4	40+	B	2
T10	1	<i>Prunus sp.</i> Cherry sp.	5.0	1	14	N 1.5	E 3.5	S 3.5	W 2.5	3.0	3.0	Semi Mature	Good	Base / stems obscured - Vegetation.	8.9	1.7	20-40	C	2
T11	1	<i>Acer pseudoplatanus</i> Sycamore	8.0	1	13	N 2.5	E 1.5	S 2.0	W 2.5	4.0	4.0	Semi Mature	Good	Base / stems obscured - Vegetation. Decay / structural defect - Principal stems.	7.6	1.6	20-40	C	2

# Corinthian Park

## Tree Survey BS5837-2012



Tree/Group Reference	Tree Count	Species	Height (m)	Stem Count	Stem Diameter (cm)	Crown Radius (m)				Crown Clearance Height (m)	Lowest Branch Height (m)	Life Stage	Physiological Condition	Observations and Recommendations	RPA (m <sup>2</sup> )	RPR (m)	Remaining Contribution (Years)	Retention Category	Retention Sub-category
T12	1	<i>Prunus sp.</i> Cherry sp.	2.5	1	10	N 0.0	E 0.0	S 0.0	W 0.0	0.0	0.0	Young	Fair				0-10	U	
T13	1	<i>Acer pseudoplatanus</i> Sycamore	8.0	1	13	N 1.5	E 2.5	S 2.5	W 2.5	3.0	3.0	Semi Mature	Good		7.6	1.6	20-40	C	2
T14	1	<i>Prunus spinosa</i> Blackthorn/Sloe	5.0	5	17	N 3.0	E 2.0	S 3.0	W 2.5	2.0	2.0	Young	Fair	Base / stems obscured - Vegetation. Ivy or climbing plant.			0-10	U	
T15	1	<i>Acer pseudoplatanus</i> Sycamore	9.0	1	19	N 2.5	E 2.5	S 2.5	W 2.5	3.0	2.5	Early Mature	Good	Base / stems obscured - Vegetation.	16.3	2.3	40+	B	2
T16	1	<i>Fraxinus excelsior</i> Ash	8.5	4	23	N 3.0	E 3.0	S 2.5	W 3.0	5.0	4.0	Early Mature	Good	Access to inspect base - Restricted / obscured. Base / stems obscured - Vegetation. Crown conflict - Structure / boundary / wire / tree.	25.2	2.8	20-40	C	2
T17	1	<i>Fraxinus excelsior</i> Ash	7.5	1	21	N 3.0	E 3.0	S 2.0	W 3.0	4.0	1.5	Semi Mature	Good	Base / stems obscured - Vegetation. Crown conflict - Structure / boundary / wire / tree. Foreign object - Ingrown metal.	20.0	2.5	20-40	C	2
T18	1	<i>Fraxinus excelsior</i> Ash	9.0	3	27	N 3.0	E 3.5	S 3.0	W 3.0	5.0	3.0	Semi Mature	Good	Base / stems obscured - Vegetation. Excavation within root zone - Recent. Excavation within root zone - Suspected. Foreign object - Ingrown metal. Ivy or climbing plant.	33.4	3.3	20-40	C	2
T19	1	<i>Fraxinus excelsior</i> Ash	9.0	3	23	N 3.0	E 3.0	S 2.0	W 1.5	5.0	3.0	Semi Mature	Fair	Base / stems obscured - Vegetation. Ivy or climbing plant.	25.6	2.9	10-20	C	2
T20	1	<i>Fraxinus excelsior</i> Ash	8.0	4	26	N 3.0	E 3.0	S 3.0	W 3.0	5.0	4.0	Early Mature	Good	Base / stems obscured - Vegetation. Ivy or climbing plant.	32.8	3.2	20-40	C	2

# Corinthian Park

## Tree Survey BS5837-2012



Tree/Group Reference	Tree Count	Species	Height (m)	Stem Count	Stem Diameter (cm)	Crown Radius (m)				Crown Clearance Height (m)	Lowest Branch Height (m)	Life Stage	Physiological Condition	Observations and Recommendations	RPA (m <sup>2</sup> )	RPR (m)	Remaining Contribution (Years)	Retention Category	Retention Sub-category
T21	1	<i>Fraxinus excelsior</i> Ash	14.5	1	55	N 7.0	E 7.0	S 7.5	W 7.0	5.0	6.0	Early Mature	Fair	Base / stems obscured - Vegetation. Die-back - Throughout crown. Ivy or climbing plant.	136.8	6.6	10-20	C	2
T22	1	<i>Fraxinus excelsior</i> Ash	9.0	2	25	N 3.0	E 2.5	S 3.5	W 3.0	5.0	4.0	Semi Mature	Fair	Base / stems obscured - Vegetation. Decay / structural defect - Major. Ivy or climbing plant.	28.3	3.0	10-20	C	2
T23	1	<i>Fraxinus excelsior</i> Ash	9.5	1	30	N 5.0	E 5.0	S 5.0	W 4.0	4.5	4.5	Early Mature	Good	Base / stems obscured - Vegetation. Ivy or climbing plant. Tree on boundary.	40.7	3.6	20-40	B	2
T24	1	<i>Fraxinus excelsior</i> Ash	9.0	1	38	N 5.0	E 5.0	S 3.0	W 5.0	4.5	5.0	Early Mature	Fair	Base / stems obscured - Vegetation. Ivy or climbing plant. Tree on boundary.	65.3	4.6	10-20	C	2
T25	1	<i>Fraxinus excelsior</i> Ash	2.5	3	36	N 2.0	E 2.0	S 2.0	W 2.0	3.0	2.5	Mature	Poor	Crown reduction - Recent.  <b>Fell - Ground level.</b> Remove low quality tree, due to conflict/unsustainable relationship with proposed development.			0-10	U	
T26	1	<i>Prunus sp.</i> Cherry sp.	6.0	1	31	N 0.0	E 3.5	S 5.0	W 2.0	4.0	2.5	Early Mature	Good	Leaning trunk - Major. Tree is outside of site boundary.	43.5	3.7	10-20	C	2
T27	1	<i>Malus sp.</i> Apple sp.	10.0	4	59	N 4.0	E 6.0	S 6.0	W 3.0	3.0	3.0	Early Mature	Fair	Base / stems obscured - Vegetation. Ivy or climbing plant. Tree is outside of site boundary.	162.2	7.2	20-40	B	2
T28	1	<i>Fraxinus excelsior</i> Ash	15.0	4	90	N 8.0	E 8.0	S 7.5	W 8.5	3.0	3.0	Mature	Poor	Altered ground level - Historic. Coppice stool - Coppice origin / Mature stems. Excavation within root zone - Historic. Root damage - Suspected.  <b>Fell - Ground level.</b> Remove tree, due to conflict/unsustainable relationship with proposed development.	366.4	10.8	10-20	C	2 3

# Corinthian Park

## Tree Survey BS5837-2012



Tree/Group Reference	Tree Count	Species	Height (m)	Stem Count	Stem Diameter (cm)	Crown Radius (m)				Crown Clearance Height (m)	Lowest Branch Height (m)	Life Stage	Physiological Condition	Observations and Recommendations	RPA (m <sup>2</sup> )	RPR (m)	Remaining Contribution (Years)	Retention Category	Retention Sub-category
G34	70	<i>Fraxinus excelsior</i> Ash	14.0	1	35	N 4.5	E 4.5	S 4.5	W 4.5	4.0	3.0	Early Mature	Good	Stem numbers are approximate. Mixed group of early mature, semi-mature, and young trees. Group is on site boundary.	55.4	4.2	20-40	B	2
	50	<i>Acer pseudoplatanus</i> Sycamore																	
	20	<i>Crataegus monogyna</i> Common Hawthorn/Quick/May																	
	15	<i>Ulmus sp.</i> Elm sp.																	
	3	<i>Malus sp.</i> Apple sp.																	
T35	1	<i>Fraxinus excelsior</i> Ash	13.0	1	35	N 4.5	E 4.5	S 4.5	W 4.5	3.0	2.0	Early Mature	Good	Fork - Cracked. <b>Fell - Ground level. Remove low quality tree, due to conflict/unsustainable relationship with proposed development.</b>			0-10	U	
G36	15	<i>Crataegus monogyna</i> Common Hawthorn/Quick/May	5.0	3	12	N 2.0	E 2.0	S 2.0	W 2.0	1.0	1.0	Semi Mature	Good	Access to inspect base - Restricted / obscured. Base / stems obscured - Vegetation. Hedgerow - Neglected / overgrown. Ivy or climbing plant. Stem numbers are approximate. Dense growth restricts access. Group is on site boundary.	6.7	1.5	10-20	C	2

# Corinthian Park

## Tree Survey BS5837-2012



Tree/Group Reference	Tree Count	Species	Height (m)	Stem Count	Stem Diameter (cm)	Crown Radius (m)				Crown Clearance Height (m)	Lowest Branch Height (m)	Life Stage	Physiological Condition	Observations and Recommendations	RPA (m <sup>2</sup> )	RPR (m)	Remaining Contribution (Years)	Retention Category	Retention Sub-category
G37	10	<i>Crataegus monogyna</i> Common Hawthorn/Quick/May	6.0	3	12	N 1.5	E 1.5	S 1.5	W 1.5	0.5	1.0	Semi Mature	Good	Access to inspect base - Restricted / obscured. Base / stems obscured - Vegetation. Hedgerow - Neglected / overgrown. Ivy or climbing plant. Stem numbers are approximate. Dense growth restricts access.	6.7	1.5	10-20	C	2
	1	<i>Ulmus sp.</i> Elm sp.																	
	1	<i>Thuja sp.</i> Thuja sp.																	
G38	18	<i>Fraxinus excelsior</i> Ash	8.0	2	16	N 2.5	E 2.5	S 2.5	W 2.5	4.0	3.0	Semi Mature	Good	Hedgerow - Neglected / overgrown. Stem numbers are approximate. Dense growth restricts access.	13.0	2.0	10-20	C	2
	5	<i>Crataegus monogyna</i> Common Hawthorn/Quick/May																	
	5	<i>Acer pseudoplatanus</i> Sycamore																	
	3	<i>Ulmus sp.</i> Elm sp.																	
G39	5	<i>Acer pseudoplatanus</i> Sycamore	7.0	2	14	N 2.0	E 2.0	S 2.0	W 2.0	3.5	3.0	Semi Mature	Good	Base / stems obscured - Vegetation. Hedgerow - Neglected / overgrown. Ulmus are dead. Stem numbers are approximate. Dense growth restricts access.	9.0	1.7	10-20	C	2
	3	<i>Fraxinus excelsior</i> Ash																	
	3	<i>Ulmus sp.</i> Elm sp.																	
G40	25	<i>Fraxinus excelsior</i> Ash	8.0	2	16	N 2.5	E 2.5	S 2.5	W 2.5	5.0	3.0	Semi Mature	Good	Base / stems obscured - Vegetation. Hedgerow - Neglected / overgrown. Stem numbers are approximate. Dense growth restricts access.	13.0	2.0	10-20	C	2

# Corinthian Park Tree Survey BS5837-2012



Tree/Group Reference	Tree Count	Species	Height (m)	Stem Count	Stem Diameter (cm)	Crown Radius (m)				Crown Clearance Height (m)	Lowest Branch Height (m)	Life Stage	Physiological Condition	Observations and Recommendations	RPA (m <sup>2</sup> )	RPR (m)	Remaining Contribution (Years)	Retention Category	Retention Sub-category
G41	40	<i>Fraxinus excelsior</i> Ash	8.5	2	14	N 2.0	E 2.0	S 2.0	W 2.0	3.0	3.0	Semi Mature	Good	Base / stems obscured - Vegetation. Hedgerow - Neglected / overgrown. Stem numbers are approximate. Dense growth restricts access. Group contains dead and dying elm.	9.0	1.7	10-20	C	2
40	<i>Crataegus monogyna</i> Common Hawthorn/Quick/May																		
8	<i>Ulmus sp.</i> Elm sp.																		
5	<i>Acer pseudoplatanus</i> Sycamore																		
2	<i>Malus sp.</i> Apple sp.																		
T42	1	<i>Betula sp.</i> Birch	7.0	1	8	N 1.0	E 1.0	S 1.0	W 1.5	2.5	2.5	Young	Fair	Young planted tree / trees. Tree planted recently by contractors. Tree may be relocated.	2.9	1.0	10-20	C	2
T43	1	<i>Betula sp.</i> Birch	7.0	1	9	N 1.0	E 1.0	S 1.0	W 1.0	2.5	2.5	Young	Poor	Young planted tree / trees. Tree planted recently by contractors. Tree may be relocated.			0-10	U	
T44	1	<i>Betula sp.</i> Birch	7.0	1	8	N 1.0	E 1.0	S 1.0	W 1.0	2.5	2.0	Young	Fair	Young planted tree / trees. Tree planted recently by contractors. Tree may be relocated.	2.9	1.0	10-20	C	2
T45	1	<i>Betula sp.</i> Birch	7.0	1	9	N 0.5	E 0.0	S 0.0	W 0.0	2.5	2.5	Young	Dead	Young planted tree / trees. Tree planted recently by contractors. Tree may be relocated.			0-10	U	
T46	1	<i>Betula sp.</i> Birch	7.0	1	8	N 1.0	E 0.5	S 0.5	W 1.0	2.5	2.5	Young	Poor	Young planted tree / trees. Tree planted recently by contractors. Tree may be relocated.			0-10	U	



# Corinthian Park Tree Survey BS5837-2012



Tree/Group Reference	Tree Count	Species	Height (m)	Stem Count	Stem Diameter (cm)	Crown Radius (m)				Crown Clearance Height (m)	Lowest Branch Height (m)	Life Stage	Physiological Condition	Observations and Recommendations	RPA (m <sup>2</sup> )	RPR (m)	Remaining Contribution (Years)	Retention Category	Retention Sub-category
T47	1	<i>Betula sp.</i> Birch	7.0	1	8	N 1.5	E 1.5	S 2.0	W 1.5	2.5	2.5	Young	Fair	Young planted tree / trees. Tree planted recently by contractors. Tree may be relocated.	2.9	1.0	10-20	C	2
T48	1	<i>Betula sp.</i> Birch	7.0	1	8	N 1.0	E 1.0	S 1.5	W 1.5	2.5	2.5	Young	Fair	Young planted tree / trees. Tree planted recently by contractors. Tree may be relocated.	2.9	1.0	10-20	C	2
T49	1	<i>Betula sp.</i> Birch	8.0	1	9	N 1.5	E 1.0	S 1.0	W 1.0	2.5	2.5	Young	Fair	Young planted tree / trees. Tree planted recently by contractors. Tree may be relocated.	3.7	1.1	20-40	C	2
T50	1	<i>Betula sp.</i> Birch	7.0	1	9	N 1.0	E 1.0	S 1.0	W 0.0	2.5	3.0	Young	Fair	Young planted tree / trees. Tree planted recently by contractors. Tree may be relocated.	3.7	1.1	10-20	C	2
T51	1	<i>Betula sp.</i> Birch	7.0	1	9	N 1.0	E 1.0	S 1.0	W 1.0	2.5	2.5	Young	Fair	Young planted tree / trees. Tree planted recently by contractors. Tree may be relocated.	3.7	1.1	10-20	C	2

# Tree Schedule Key



<b>Tree/Group Reference</b>	Reference number for individual trees or groups of trees, prefixed by T (Tree), G (Group), W (Woodland), H (Hedge) or S (Shrub) to indicate the type of feature.
<b>Tree Count</b>	Number of trees of a particular species recorded within a group feature, with the default value of 1 for single trees.
<b>Species</b>	Scientific name followed by common name (where available).
<b>Height (m)</b>	Tree height to the nearest metre, either measured with a device or estimated. Tree height for group records refers to the estimated average height of trees within the group (unrepresentative trees may be excluded from this estimate).
<b>Stem Count</b>	Number of stems. Stem count indicates whether the tree is single-stemmed or multi-stemmed and informs the RPA calculation.
<b>Stem Diameter (cm)</b>	Stem diameter, measured at 1.5m above ground level in accordance with Annex C of BS5837:2012. Diameters of multi-stemmed trees are presented as a combined stem diameter calculated in accordance with the formulae in Section 4.6.1 of BS5837:2012. Stem diameter for group records refers to the estimated average stem diameter of trees within the group (unrepresentative trees may be excluded from this estimate).
<b>Crown Radius (m)</b>	Distance from stem position to crown periphery in either the four cardinal or four ordinal directions, estimated to the nearest half metre. Crown spreads for group records refer to the estimated average spreads of trees within the group (unrepresentative trees may be excluded from this estimate).
<b>Crown Clearance Height (m)</b>	Distance between the ground and the lowest point of the crown periphery, estimated to the nearest half metre.
<b>Lowest Branch Height (m)</b>	Height of the lowest branch, the removal of which is considered likely to have a significant negative effect on the tree in terms of physiology or in terms of the size of wound created.
<b>Life Stage</b>	Young, Semi-mature, Early Mature, Mature, Late Mature, Ancient or Veteran.
<b>Physiological Condition</b>	Good, Fair, Poor, Dead.
<b>Observations</b>	General description of the tree or tree group, including basic features and morphology, structural and physiological condition, growing conditions and surroundings.
<b>Recommendations</b>	Management recommendations for tree works to address immediate unacceptable risks, or to facilitate development proposals.
<b>RPA (m<sup>2</sup>)</b>	Minimum area around a tree deemed to contain sufficient roots and rooting soil volume to maintain the tree's viability, in which the protection of roots and soil structure is treated as a priority. Calculated from the stem diameter according to the formulae in BS5837:2012. RPA for group records is based on the estimated average stem diameter of trees within the group (unrepresentative trees may be excluded from this estimate).
<b>RPR (m)</b>	Radius of the RPA, in metres, when this is plotted as a circle around the tree stem.
<b>Remaining Contribution (years)</b>	Estimated number of years for which the tree will continue to make a positive contribution to the site, banded as < 10, 10-20, 20-40, 40 +.
<b>Retention Category</b>	Quality and value category ( <b>A</b> , <b>B</b> , <b>C</b> or <b>U</b> ) as defined in Table 1 of BS5837: 2012 (reproduced below), where <b>A</b> = high quality and value; <b>B</b> = moderate quality and value; <b>C</b> = low quality and value and <b>U</b> = tree identified for removal due to poor condition regardless of development proposals.
<b>Retention Sub-category</b>	One or more sub-categories (1-3) as defined in Table 1 of BS5837: 2012 (reproduced below), assigned for Categories <b>A</b> , <b>B</b> or <b>C</b> where 1 = arboricultural qualities, 2 = landscape qualities and 3 = conservation and cultural value.

## **Appendix B**

---

### **Tree Protection Plan**

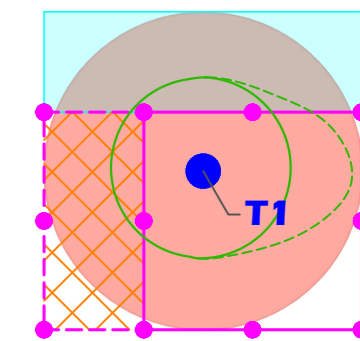
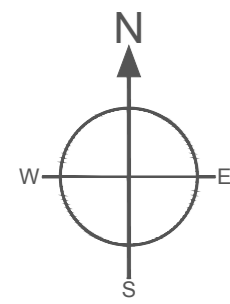

- T1 Tree or Group Reference Number
- Tree Stem Position A Category Tree
- Tree Stem Position B Category Tree
- Tree Stem Position C Category Tree
- Tree Stem Position U Category Tree
- Tree Crown
- Root Protection Area
- Tree Protection Fencing
- Initial Tree Protection Fencing
- Ground Protection
- Special Engineering /Supervised Excavations
- Construction Exclusion Zone
- Pruning/Tree Removal
- Site Boundary

Date: February 2018

Scale: 1:1000 @ A2

Project Name: Corinthian Park

Drawing Title: Tree Protection Plan

Drawing Number: 180228-2.1-CPC-TTP-NC



Treework Environmental Practice  
 Monarch House  
 1-7 Smyth Road  
 Bedminster  
 Bristol  
 BS3 2BX

Tel: 0117 244 0012  
 Web: www.treeworks.co.uk  
 Email: info@treeworks.co.uk



## **Appendix C**

---

### **Tree Constraints Plan**

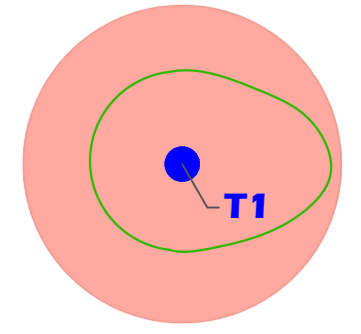
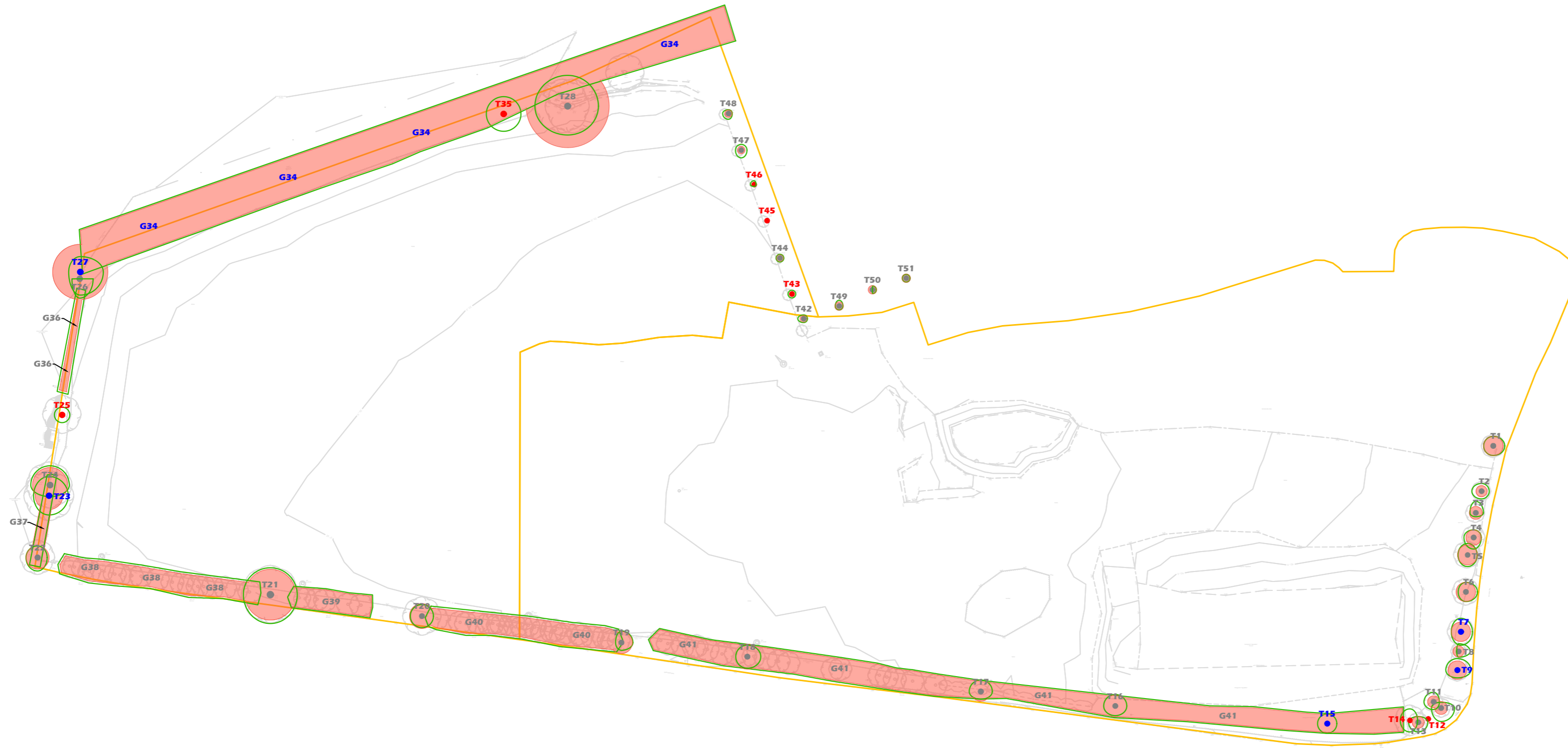
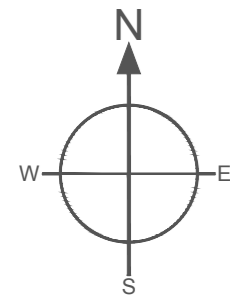

- |                                |                                    |
|--------------------------------|------------------------------------|
| Tree or Group Reference Number | Tree Stem Position A Category Tree |
| Tree Crown                     | Tree Stem Position B Category Tree |
| Root Protection Area           | Tree Stem Position C Category Tree |
| Tree Survey Boundary           | Tree Stem Position U Category Tree |

Date: February 2018

Scale: 1:1000 @ A2

Project Name: Corinthian Park

Drawing Title: Tree Constraints Plan

Drawing Number: 180227-2.0-CPC-TCP-NC



Treework Environmental Practice  
Monarch House  
1-7 Smyth Road  
Bedminster  
Bristol  
BS3 2BX

Tel: 0117 244 0012  
Web: [www.treeworks.co.uk](http://www.treeworks.co.uk)  
Email: [info@treeworks.co.uk](mailto:info@treeworks.co.uk)

## **Appendix D**

---

### **Tree Protection Specifications**

## Technical Measures to Prevent Tree Damage

### Tree Pruning

Tree pruning will be carried out where the design and/or planned site operations encroach into the crowns of trees and where these encroachments can be accommodated through facilitation pruning without significantly reducing the landscape value and/or viability of the tree.

Tree pruning operations will:

- be specified by the arboricultural consultant
- be in accordance with current best practice
- be carried out by a suitably experienced and qualified arborist

### Tree Protection Fencing

Tree protection fencing will be located at the edge of the Construction Exclusion Zone (CEZ) and will be suitably robust to provide sufficient protection for trees. The performance requirement for fencing will be determined by the type of activity that will take place in the area around the CEZ.

Typically the performance requirement for the Tree Protection Fencing will be:

- Tree Protection Fencing will be installed prior to commencement of activity on the site.
- Tree Protection Fencing will only be removed once all works associated with the development have been completed.
- The Tree Protection Fencing will be installed and removed without causing damage to retained trees.
- Installation, removal and, where required, replacement of Tree Protection Fencing will be supervised and signed off by the Arboricultural Consultant.
- The Tree Protection Fencing will be stable and robust (typical construction method, in accordance with BS5837: 2012, see below).
- The area between the Tree Protection Fencing and the tree will be a Construction Exclusion Zone (CEZ)
- Fence panels will be made of mesh (e.g.: Heras fencing) or, if solid, will have 30cm windows cut into enough panels to enable conditions within the CEZ to be viewed.
- The CEZ will be clearly identified (see Construction Exclusion Zone sign example below)





**Example Tree Protection Fencing Sign**

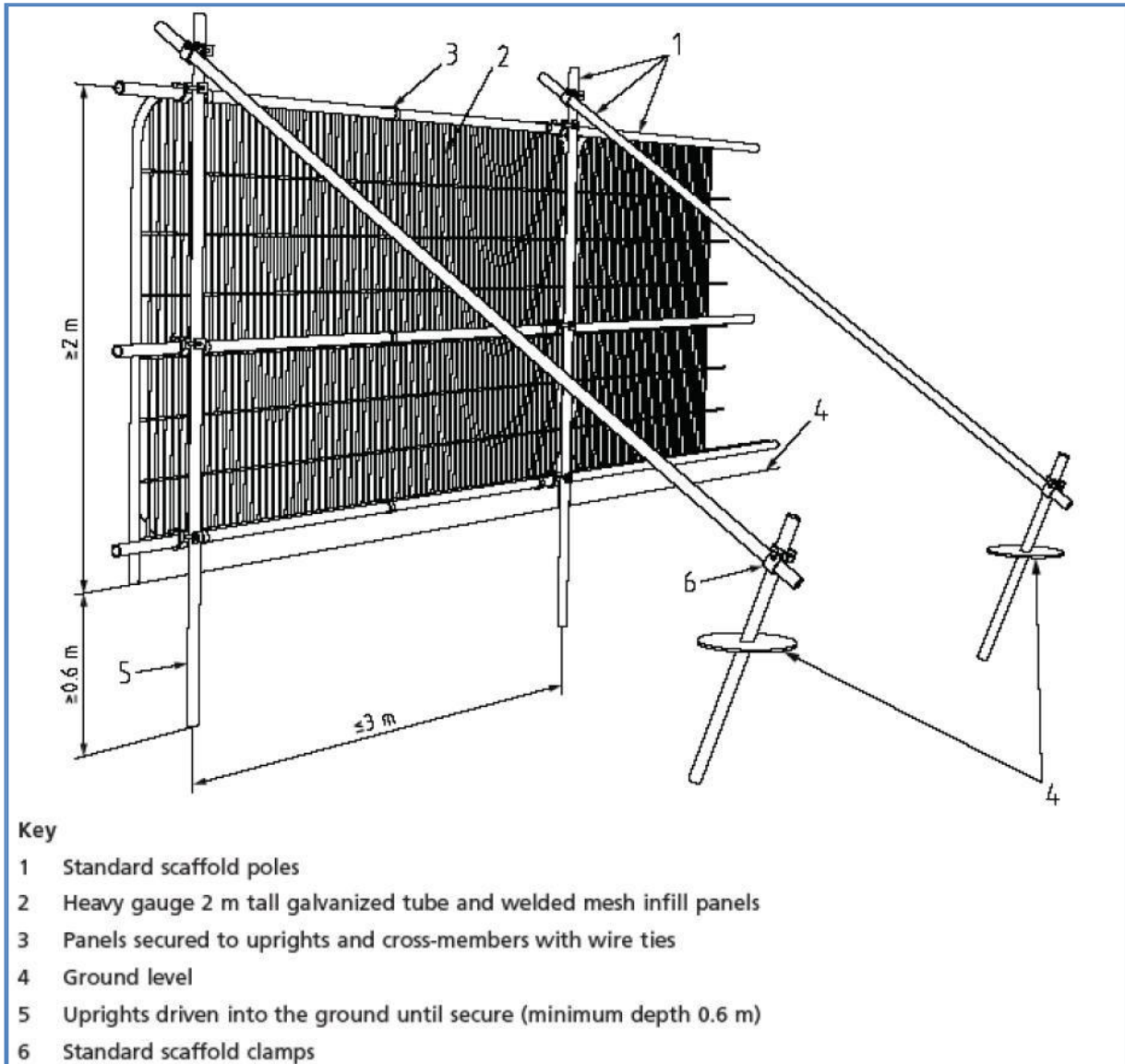

**BS5837: 2012 - Figure 2 – Tree Protective Barrier**

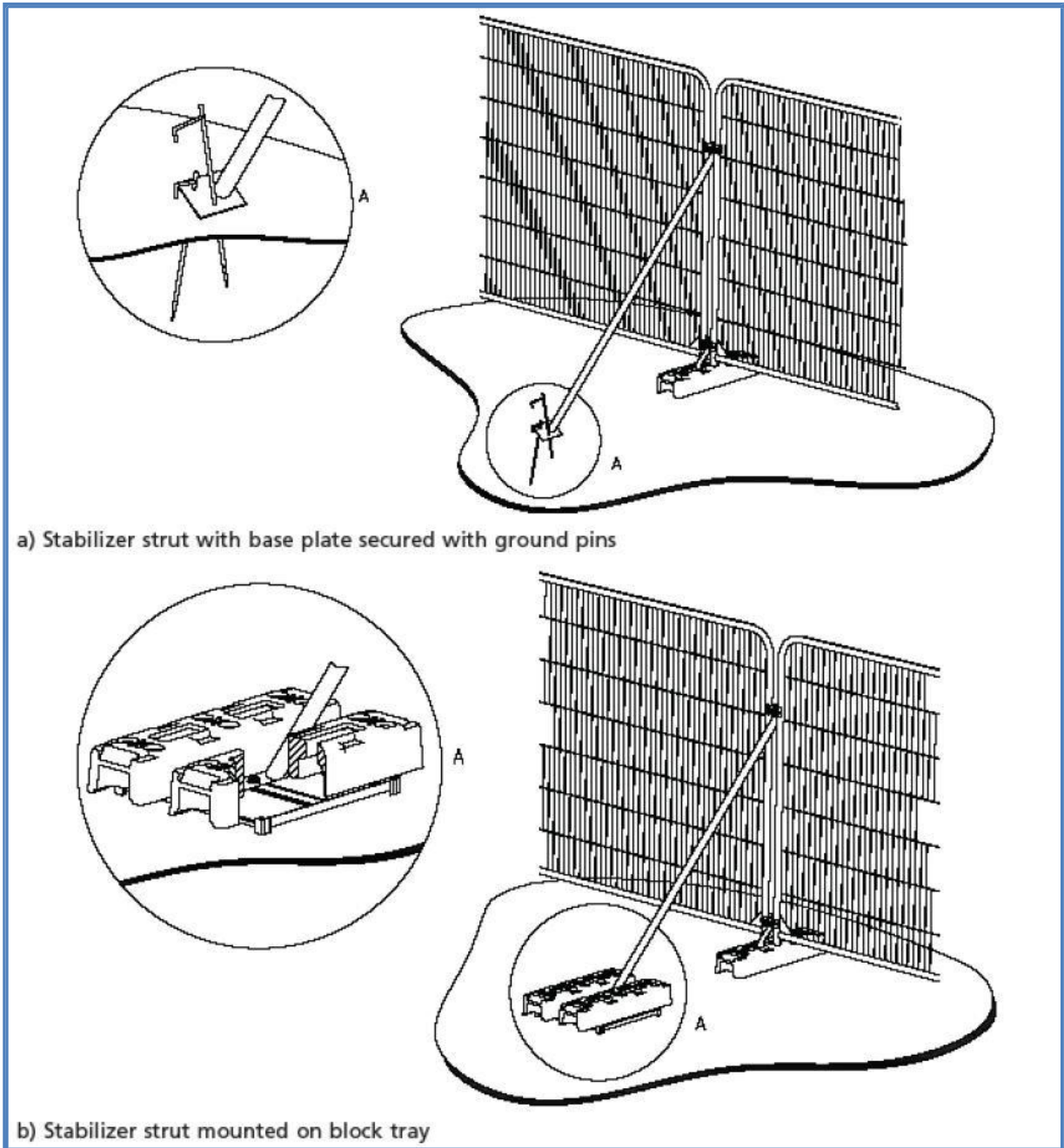

BS5837: 2012 - Figure 3 – Examples of Above Ground Stabilisation Systems

## **Appendix E**

---

### **Tree Survey Method and Limitations**

## Tree Survey Method and Limitations

---

### Tree Survey Method

1. The tree survey was conducted from ground level aided by the Visual Tree Assessment method (Mattheck and Breloer, 1994) and in accordance with BS5837: 2012.
2. All trees on the site with a stem diameter of over 75 mm (measured at 1.5 m above ground) were included in the survey.
3. Offsite trees within influencing distance of the site (typically those located within a distance of up to 12 times their stem diameter away from the site) were included in the survey.
4. Data collected included:
  - a designated tree number
  - type of feature (trees, group, woodland, hedge)
  - number of trees in group
  - tree species
  - height (metres)
  - number of stems
  - stem diameter (in centimetres, as measured at 1.5 m above ground)
  - crown clearance (height of periphery of crown spread above ground level in metres)
  - height of lowest branch (metres),
  - branch spread (to N, S, E and W)
  - age class
  - physiological condition
  - useful life expectancy
  - structural condition
  - BS5837 retention category (A, B, C or U)
  - site notes (where this has a bearing on the present or future health or structural condition of the tree)
  - preliminary management recommendations.
5. All measurements were made in metric using measuring devices where applicable. Estimated stem diameters (e.g., due to lack of access or dense undergrowth) were recorded as such and are shown in the Tree Schedule in bold (see the key at the end of the Tree Schedule table at Appendix A for an explanation of the measurements and codes presented therein).
6. While the appraisals of the surveyed trees are not tree risk assessments, they nonetheless take into account observed structural defects in drawing conclusions about the trees' retentive worth.

## Survey Limitations

1. The survey was a preliminary assessment from ground level and observations were made solely from visual inspection for the purposes of an assessment relevant to planning and development. Only binoculars, trowel, mallet and fine manual metal probe were used to aid tree assessment, where necessary. No invasive or other detailed internal decay detection devices were used in assessing trunk condition.
2. The conclusions relate to conditions found at the time of survey. Any significant alteration to the site that may affect the trees that are present or have a bearing on the planning implications (including level changes, hydrological changes, extreme climatic events or other site works) will require a re-assessment of the trees and the site.
3. This survey is not a tree safety inspection. It is carried out in order to inform the planning process. Where clear and obvious hazards have been observed, these have been addressed in the recommendations (see Appendix A - Tree Schedule). A full assessment of the levels of risk posed by trees would need to consider site use together with tree hazards.